

HAFU-AC1-2X4

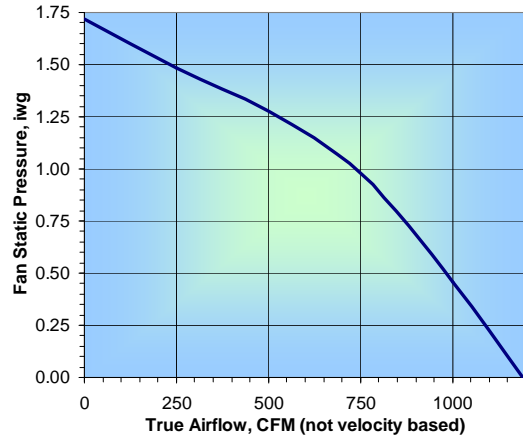
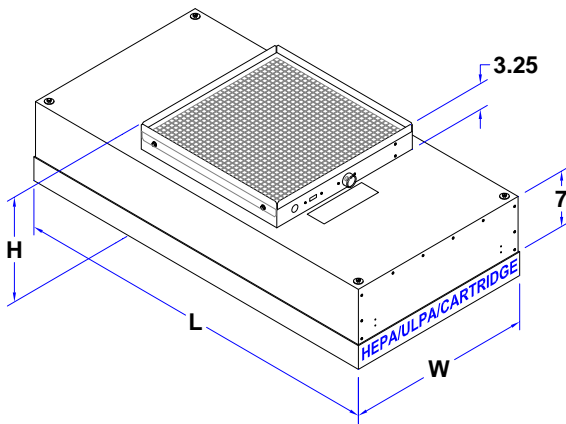

24"x48" grid centerlines	Part that mates to grid		Filter		Fan housing		Overall	
Loading and grid style	Grid surface	W	L	Width	Length	Width	Length	H
<input type="checkbox"/> Top load light weight T grid	Gasket			23.63	47.63	23.38	47.38	13.25
<input type="checkbox"/> Top load heavy duty 2" T grid	Gasket			22.75	46.75	22.5	46.5	13.25
<input type="checkbox"/> Top load flush 2.0 grid	<input type="checkbox"/> Gasket <input type="checkbox"/> Gel			22.75	46.75	22.5	46.5	13.25
<input type="checkbox"/> Room side replaceable cartridge on flush 2.0 grid	<input type="checkbox"/> Gasket <input type="checkbox"/> Gel	22.75	46.75	21.1	45.1	21.0	45.0	17.25
<input type="checkbox"/> Bottom load flush 2.0 grid	Downward facing knife-edge			20.63	44.63	18.8	42.8	14
<input type="checkbox"/> Other								

Filter efficiency	<input type="checkbox"/> HEPA 99.99% 0.3 microns	<input type="checkbox"/> ULPA 99.9995% 0.12 microns
Filter pack depth	<input type="checkbox"/> 53 mm (2") Standard	<input type="checkbox"/> 70 mm (3")
Input power	<input type="checkbox"/> 115VAC single phase 60 Hz	<input type="checkbox"/> 277VAC single phase 60 Hz

Part number	Accessory
29-50100	Inlet duct adaptor 10" collar
29-50120	Inlet duct adaptor 12" collar

Voltage	Max W	Full Speed Max Amps	Unit Label FLA
115VAC	200	1.8	2.25
277VAC	190	0.9	1.25

Velocity, FPM	SP, iwg	Single Unit Sound Power Levels, dB re 1 pico Watt							
		63	125	250	500	1K	2K	4K	LwA
90	0.5	53	60	60	50	49	45	43	56
90	1.1	56	73	65	56	53	48	44	62

FFU Specification [Optional items]

Fan housing shall be powder-coated steel or galvalume. Unit shall incorporate a sound baffle with sound absorbent insulation. Unit shall carry an ETL listing per UL 1995.

The nominal 2x4 foot FFU shall be capable of producing a minimum of 720 cfm of true airflow (not a velocity based reading) at 1 iwg of fan static pressure. The fan shall consist of an integrated motor and centrifugal plug fan. The impeller shall have single-sided suction with backward-curved blades made of aluminum and be mounted directly to the rotor of the motor. Motor shall be single phase external rotor motor with permanently lubricated ball bearings. The fan assembly shall be statically and dynamically balanced as per ISO 1940, class G 6.3. Housing shall incorporate a finger guard on the inlet side of the fan that requires tooled removal.

Provide a triac type manual speed controller and on/off switch located on the top of the FFU housing. Power input to the unit shall be 115VAC [277VAC] 60 Hz. Provide a 6 foot flexible cord with plug for 115VAC units. [277VAC units will need to be wired in the field by a licensed electrician.]

Provide a 1" thick 20"x20" 30% pre-filter mounted on top of the unit. Provide a plenum style final filter with a 2 inch pack depth with an anodized extruded aluminum frame. HEPA filter shall have a minimum DOP efficiency of 99.99% @ 0.3 microns. [ULPA filter shall have a minimum DOP efficiency of 99.9995% @ 0.12 microns.] The filter shall have a flat bottom face for seating onto gasketed grid. The final filter shall have a coated metal screen on the downstream face to protect the filter. The fan housing shall sit directly on the final filter with a gasket seal between.