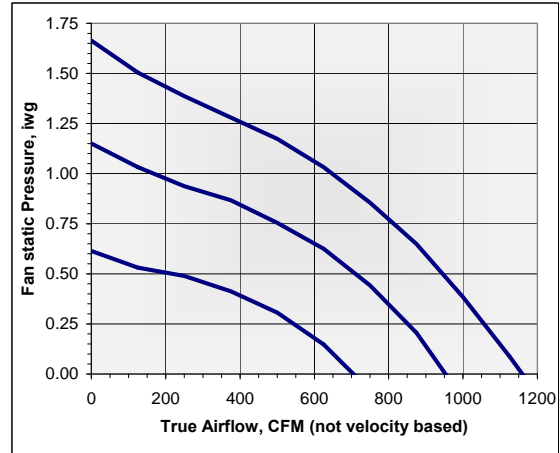
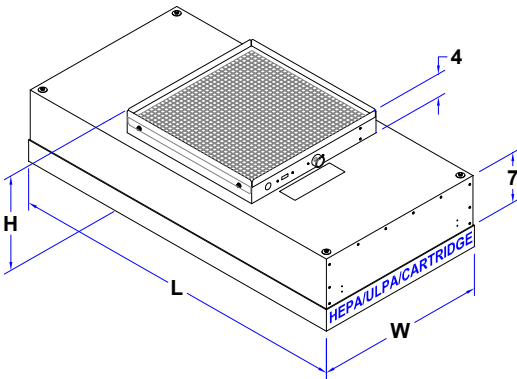

HAFU-DC-EB-2X4

Voltage	Max W	Unit Label FLA
200-277VAC	170	2.0

Can be custom rated at lower FLA

24"x48" grid centerlines		Part that mates to grid		Filter		Fan housing		Overall	
Loading and grid style		Grid surface	W	L	Width	Length	Width	Length	H
<input type="checkbox"/>	Top load light weight T grid	Gasket			23.63	47.63	23.38	47.38	14
<input type="checkbox"/>	Top load heavy duty 2" T grid	Gasket			22.75	46.75	22.5	46.5	14
<input type="checkbox"/>	Top load flush 2.0 grid	<input type="checkbox"/> Gasket <input type="checkbox"/> Gel			22.75	46.75	22.5	46.5	14
<input type="checkbox"/>	Room side replaceable cartridge on flush 2.0 grid	<input type="checkbox"/> Gasket <input type="checkbox"/> Gel	22.75	46.75	21.1	45.1	21.0	45.0	18
<input type="checkbox"/>	Bottom load flush 2.0 grid	Downward facing knife-edge			20.63	44.63	18.8	42.8	14.75
<input type="checkbox"/>	Other								

Filter efficiency	<input type="checkbox"/> HEPA 99.99% 0.3 microns	<input type="checkbox"/> ULPA 99.9995% 0.12 microns
Filter pack depth	<input type="checkbox"/> 53 mm (2") Standard	<input type="checkbox"/> 70 mm (3")
Input power	<input type="checkbox"/> 200-277VAC single phase 50/60 Hz	

Sound at Varying Static Pressures

Point	Velocity, FPM (m/s)	SP, iwg (Pa)	Speed, RPM	Lw / Lp	Octave Band Center Frequencies, Hz						A-weighted	
					63	125	250	500	1K	2K		4K
A	90 (0.45)	0.39 (97)	1086	Lw	53	63	57	52	50	46	36	56
				Lp	52	57	51	46	47	42	34	51
B	90 (0.45)	0.50 (124)	1157	Lw	54	69	60	56	52	48	38	59
				Lp	54	65	55	51	50	46	37	55
C	90 (0.45)	0.75 (187)	1353	Lw	60	71	65	60	57	53	44	63
				Lp	60	66	62	57	54	51	42	60
D	90 (0.45)	0.87 (216)	1426	Lw	61	72	67	62	58	54	45	65
				Lp	61	66	62	58	55	51	43	61

Lw is Sound Power Level, dB re 1 pico Watt.

Lp is single unit Sound Pressure Level, db re 20 micro Pa, at a distance of 1 m from filter face

Power Consumption, Power Factor and Harmonics

Point	Irms	P (W)	S (VA)	Q (VAR)	PF	Φ (deg)	Vthd, %	Ithd, %	Ifund, A	I 3 rd har, A	I 5 th har, A	I 3 rd har, %	I 5 th har, %
A	0.62	62	73	39	0.84	32	2.1%	28%	0.59	0.14	0.06	25%	10%
B	0.79	84	93	42	0.90	26	2.1%	21%	0.77	0.14	0.06	18%	7%
C	1.14	127	134	44	0.94	19	2.0%	15%	1.12	0.14	0.05	13%	5%
D	1.23	144	151	46	0.95	18	2.2%	14%	1.28	0.15	0.06	12%	4%

Harmonics are as percentage of fundamental.

Control and Monitoring Options

- Local manual speed control
- ModBus RTU with small control console
- ModBus RTU for direct control from building management system



11555 SW Myslony St.
Tualatin, Oregon 97062
503-639-0113

CPFFU-DC-EB-2X4

FFU Specification [Optional items]

Fan housing shall be powder-coated steel [aluminum] [galvalume]. Unit shall incorporate a sound baffle with sound absorbent insulation. Unit shall carry an ETL listing per UL 1995.

The nominal 2x4 foot FFU shall be capable of producing a minimum of 720 CFM (1223 CMH) of true airflow (not a velocity based reading) at 0.8 iwg (200 Pa) of fan static pressure. The fan shall consist of an integrated motor and centrifugal plug fan. The impeller shall backward-curved blades made of aluminum and be mounted directly to the rotor of the motor. Motor shall be an electronically commutated brushless DC external rotor motor with permanently lubricated ball bearings. The controller shall have active power factor correction. The total current harmonic distortion (Ithd) as a percentage of fundamental shall be no higher than 15% at full speed and no higher than 30% at any speed. The power factor shall be no lower than 95% at full speed and no lower than 84% at any speed. The fan assembly shall be statically and dynamically balanced as per ISO 1940, class G 6.3. Housing shall incorporate a finger guard on the inlet side of the fan that requires tool removal. Power input to the unit shall be 200-277VAC 50/60 Hz.

[Provide a 1" (25 mm) thick 20"x20" (500x500 mm) 30% pre-filter mounted on top of the unit.] Provide a plenum style final filter with a 50 [70] [100] mm pack depth with an anodized extruded aluminum frame. HEPA filter shall have a minimum DOP efficiency of 99.99% @ 0.3 microns. [ULPA filter shall have a minimum DOP efficiency of 99.9995% @ 0.12 microns.] The filter shall have a flat bottom face for seating onto gasketed grid. The final filter shall have a coated metal screen on the downstream face to protect the filter. The fan housing shall sit directly on the final filter with a gasket seal between. [Provide an intermediate cartridge with gel seal final filter to enable removal of filter without removing fan housing.]